

Deadlatch Strikes For Aluminum Frame/Doors

4901, 4902

For use with 4900/4500/4700 Deadlatches

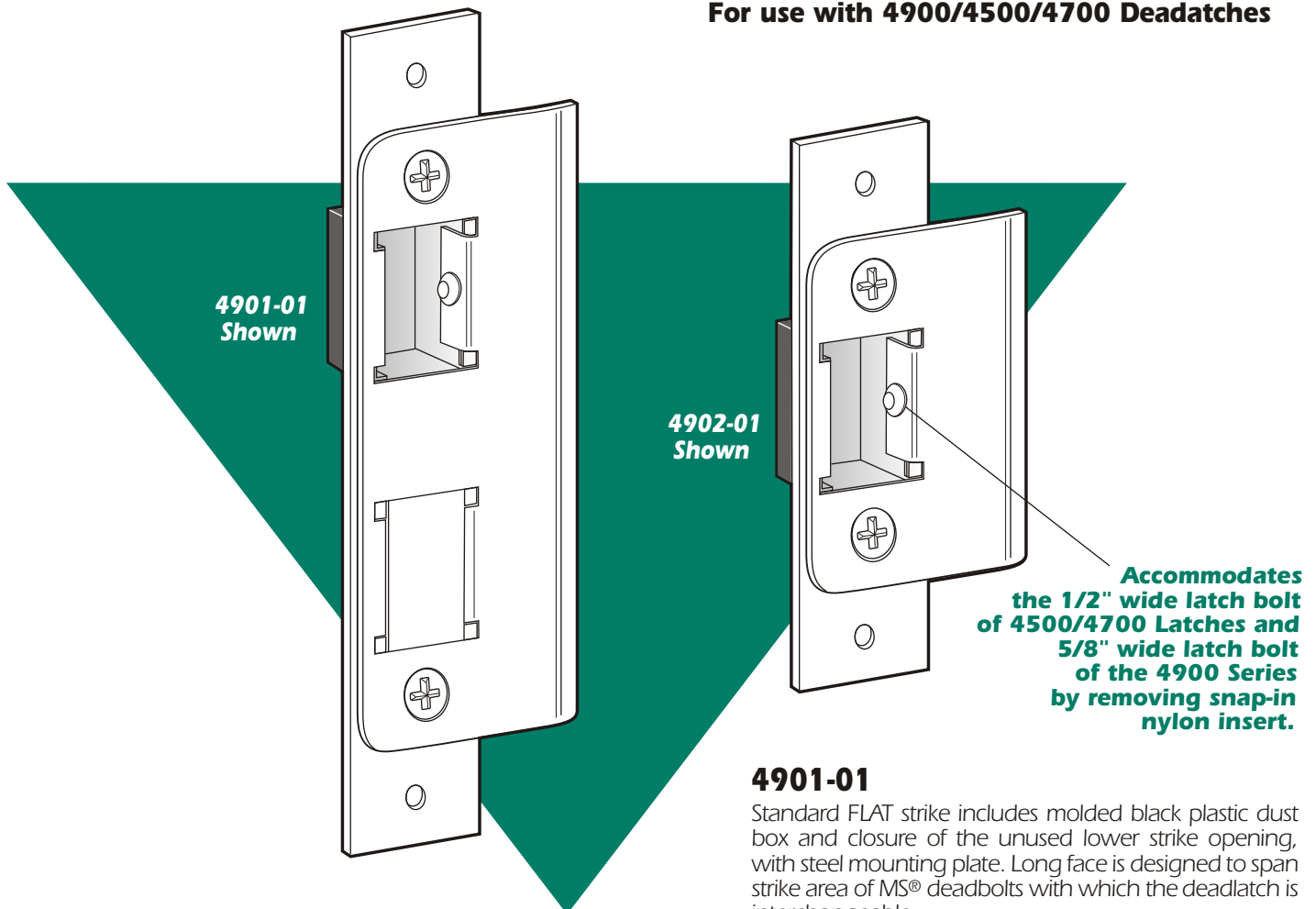

4901-01

Standard FLAT strike includes molded black plastic dust box and closure of the unused lower strike opening, with steel mounting plate. Long face is designed to span strike area of MS® deadbolts with which the deadlatch is interchangeable.

4901-02

Same as 4901-01, except with RADIUSSED strike plate, for nose of opposite door when latching pairs.

4902-01

Standard FLAT strike furnished with the 4900 Series deadlatches. Includes molded black plastic dust box and steel mounting plate. Short face design.

4902-02

Same as 4902-01, except with RADIUSSED strike plate, for nose of opposite door when latching pairs.

Function

Designed for use in conjunction with 4500, 4700 or 4900 Series deadlatches, these strikes offer a choice of mounting methods: a back-up mounting plate included with the 4901 and 4902 allows installation flush in a hollow section jamb. Use 4506-02 ANSI strike for wood or steel jambs. All strikes are unhandled, suitable for right or left hand doors. Strike plate material is stainless steel.



4901/02 Deadlatch Strikes

DIMENSIONS

INCHES

MILLIMETERS

Nominal, subject to tolerance extremes.

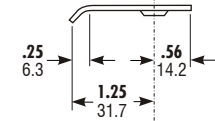
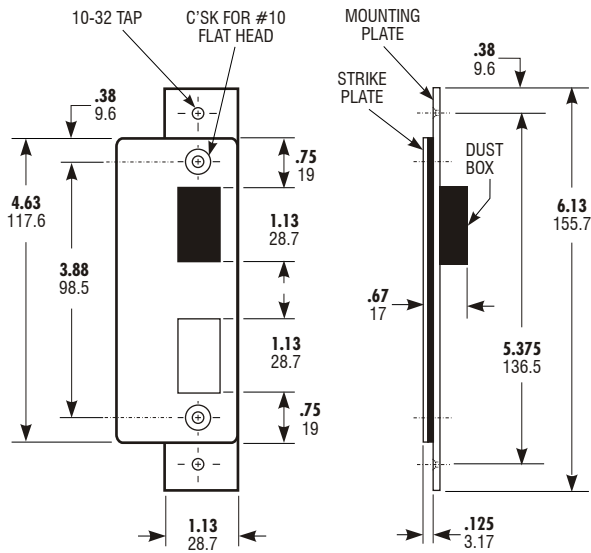

4901-01 FLAT
with Dust Box &
Mounting Plate

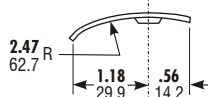

4901-02 RADIUS
with Dust Box &
Mounting Plate

JAMB PREPARATION

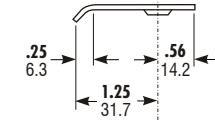
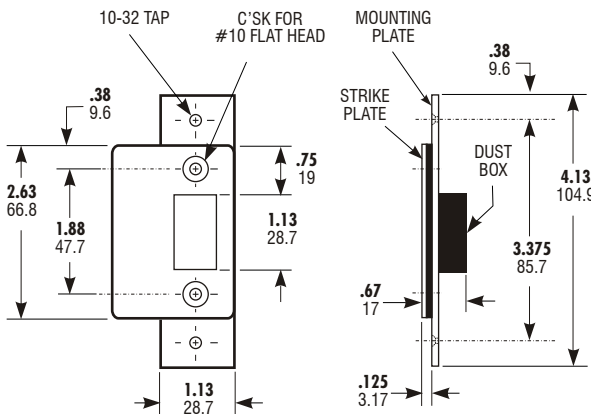
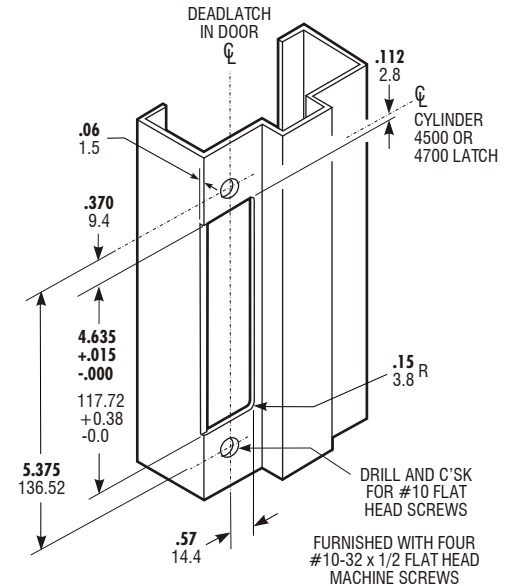

4902-01 FLAT
with Dust Box &
Mounting Plate

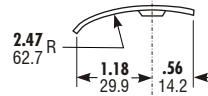

4902-02 RADIUS
with Dust Box &
Mounting Plate

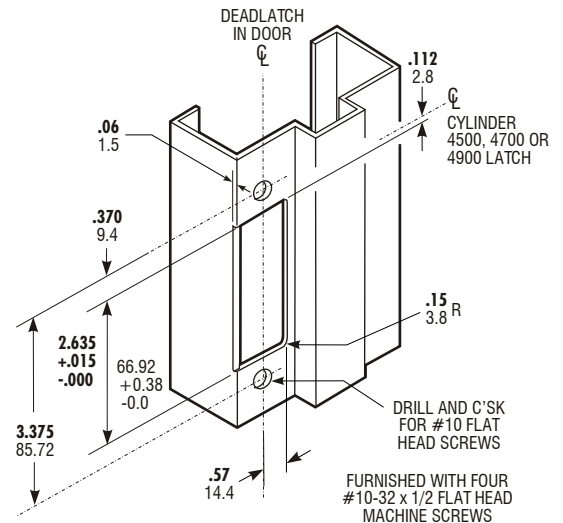

HOW TO ORDER/OPTIONS

Specify quantity, PART NUMBER and DASH NUMBER.
Order wood screws separately.

Part No. Long Type Strike

| | |
|---------|--|
| 4901-01 | FLAT, with Dust Box and Mounting Plate |
| 4901-02 | RADIUS, with Dust Box and Mounting Plate |

Part No. Short Type Strike

| | |
|---------|--|
| 4902-01 | FLAT, with Dust Box and Mounting Plate |
| 4902-02 | RADIUS, with Dust Box and Mounting Plate |

Long Lip for Centerhung Door

Replace -01 with:

| DASH | FOR CENTER OF: | DIM. "A" |
|------|-----------------|----------|
| -03 | 2.25" Wide Jamb | 1.125 |
| -05 | 2.50" Wide Jamb | 1.25 |
| -07 | 2.75" Wide Jamb | 1.375 |
| -09 | 3.00" Wide Jamb | 1.50 |
| -11 | 3.25" Wide Jamb | 1.625 |
| -13 | 3.50" Wide Jamb | 1.75 |
| -15 | 3.75" Wide Jamb | 1.875 |
| -17 | 4.00" Wide Jamb | 2.00 |
| -19 | 4.25" Wide Jamb | 2.125 |
| -21 | 4.50" Wide Jamb | 2.25 |

